

# SPECIFICATIONS

S.I. MODEL		A10N4	A25N4	ALS10N4	ALS25N4	
TORQUE RANGE N · m	Min - Max.	2 - 10	5 - 25	2 - 10	5 - 25	
	Grad.	0.1	0.25	0.1	0.25	
METRIC MODEL		A100M4	A250M4	ALS100M4	ALS250M4	
TORQUE RANGE kgf · cm	MIN. - MAX.	20 - 100	50 - 250	20 - 100	50 - 250	
	Grad.	1	2.5	1	2.5	
AMERICAN MODEL		A100I4-3/8	A200I4-3/8	ALS100I4-3/8	ALS200I4-3/8	
TORQUE RANGE lbf · in	MIN. - MAX.	20 - 100	50 - 200	20 - 100	50 - 200	
	Grad.	1	2.5	1	2.5	
Max. provisional Torque N · m		1.8				
Free [rpm]		750				
Air pressur [Mpa]		0.5				
Dimensions [mm]	Effective length	L	149	162	149	162
	Overall length	L'	204	217	204	217
	Hight	H	74.7			
	Head	R	13			
	Square drive	a	9.53			
		b	21.5			
		c	10.4			
		φD	12			
	Switch	E	-	-	34.5	33
		F	-	-	13.5	22.7
Weight [kg]		0.59	0.61	0.71	0.77	
Limit switch		N/A		Avaiable		

Standard accessory: Hex key W2.5

# DIMENSIONS

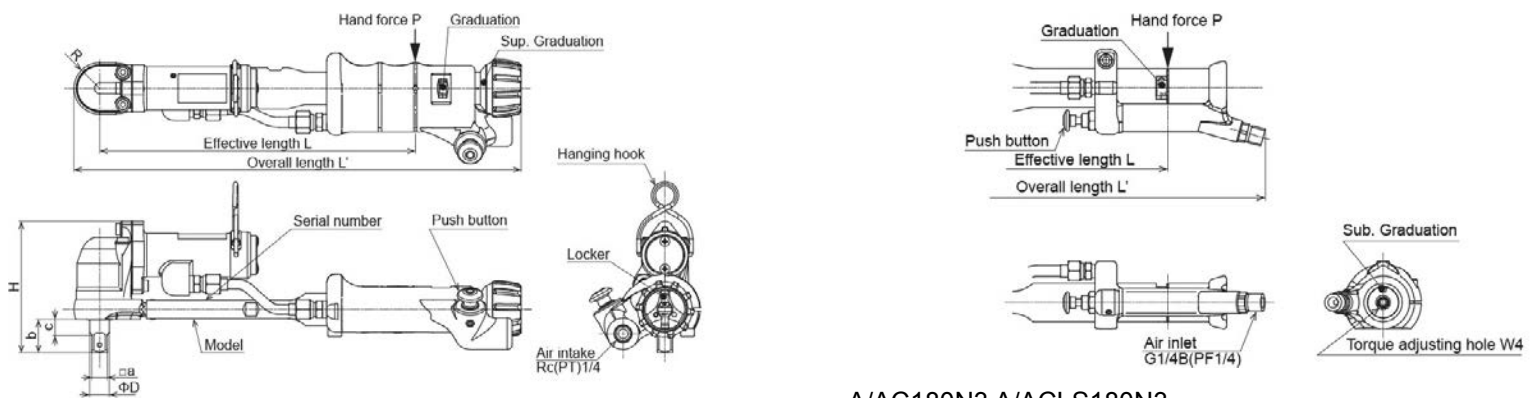

A3

A/AC180N3 A/ACLS180N3

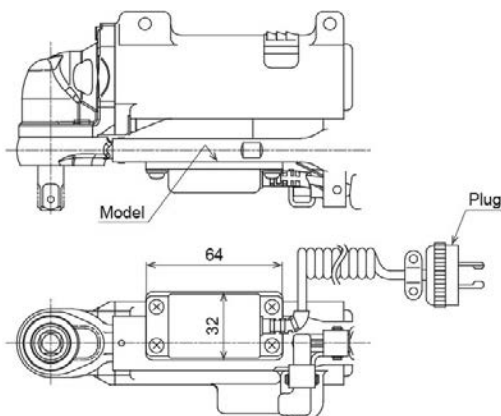

A/ACLS3 Limit switch