

ROTARY PEAK TORQUE METER SPINTORK MODEL ST3-G-BT

OPERATING INSTRUCTION

ST3-G-BT **ST3-G-BT Model**



CE

To use this product properly and safely, please read this manual carefully before use. If you have any question about the product and its operations, please contact your nearest distributor or TOHNICHI MFG. CO., LTD.

Safety Precautions

- (1) Prior to using the product, read Safety Precautions thoroughly for correct operation.
- (2) Observe the precautions herein. They describe significant information related to safety.

The following describes the meanings of indications.

Safety Symbol





This symbol is used for drawing attention to "safety precautions". If you see this symbol in this operating instruction, attention should be paid to safety. Take preventative actions according to the description and conduct "safe operations and proper control".

Signal Words

The signal words are the headers which indicate the level of hazard that should be known for human safety and in handling devices. The signal words for safety are "Danger", "Warning" and "Caution" depending on the level of hazard to human. The signal words are used with the safety symbol to indicate the following situations.

" Danger": Imminent danger which may cause serious damage.

" Warning": Potential danger which may cause serious damage.

" Caution": Potential danger which may hinder ordinary operation but may not lead to serious damage.

 **Warning**

- **Do not use the product in an atmosphere exposed to flammable gas and steam.**
 - Failure to observe this may cause a fire.
- **Use a special-purpose charger and storage battery.**
 - Use only the charger and storage battery specified in this operating instruction.
- **Charge the product in a correct manner.**
 - Use this charger only with the power supply where the ratings are indicated. Failure to observe this may generate abnormal heat, resulting in a fire.
 - In case the temperature is less than 0°C or 40°C or more, do not charge the storage battery. Failure to observe this may result in a burst or fire.
 - Charge the storage battery in a well-ventilated place.
 - Overcharge may cause the storage battery to burst or generate heat.

- Do not cover the charger and storage battery with cloth, etc. Failure to observe this may result in a burst or fire.
- When not using, disconnect an AC adapter plug from the power supply. Failure to observe this may result in an electric shock or fire.
- **Do not throw the storage battery into fire.**
 - Failure to observe this may cause the storage battery to burst or produce a harmful material.
- **Prohibition of disassembling and remodeling the product**
 - Failure to observe this may impair safety, deteriorate the functions and service life, or result in trouble.
- **Consider the ambient circumstances of the workplace.**
 - Do not use the main body, charger and storage battery in the rain or in a moist (wet) place. Failure to observe this may result in an electric shock, fuming or trouble.
 - Fully illuminate the workplace. Working in a dark place leads to an accident.
 - Do not use or charge the product in a place where a combustible liquid or gas is generated. Failure to observe this may result in an explosion or fire.
- **Take a measure to prevent a fall of socket, etc.**
 - A fall of main body, socket or extension bar results in an accident, injury or trouble. Take a proper measure such as attaching a fall preventive pin.
- **Be sure to use specified accessories and optional articles.**
 - Use only the accessories and optional articles specified in this operating instruction. Failure to observe this may result in an accident or injury.



- **Do not use or store the product in a high-temperature high-humidity place, dusty place, place where water may be allowed into the product, place exposed to violent vibrations, unstable place, and so on.**
 - Failure to observe this may result in trouble of the product body.
- **Do not put or drop metal pieces or flammable substances into the product through an opening.**
 - Failure to observe this may result in trouble of the product.
- **Store the product properly when not used.**
 - Store it in a dry keyed place. Failure to observe this may result in an injury or accident.

- Do not store the main body and storage battery in a place likely to have a temperature increase of up to 50°C or more. Failure to observe this may deteriorate the storage battery, resulting in fuming or ignition.
- **Do not handle the charger's cord in a rough manner.**
 - Do not hold the cord to carry the charger or pull it to disconnect from a plug socket. Failure to observe this may damage it.
 - Do not expose the cord to the heat, oil or a pointed corner.
 - Care should be taken to choose where to charge so that the cord will not be stamped on, tripped over or damaged by an excessive force.
 - Failure to observe this may lead to an electric shock or short-circuit, resulting in ignition.
- **Carry out maintenance carefully.**
 - To replace the accessories, follow the instructions in this operating instruction. Failure to observe this may result in trouble.
 - Inspect the charger's cord periodically. If damaged, contact our distributor or TOHNICHI MFG. CO., LTD. for repair. Failure to observe this may lead to an electric shock or short-circuit, resulting in ignition.
- **Check for any damaged part.**
 - Prior to using the product, check the case and other parts fully for any damage, and whether it works successfully and exhibits specified functions.
 - Check for damage on parts, their mounting condition, and all the parts which may affect work for any abnormality.
 - Do not use the charger with damaged power plug or cord, or the one damaged somehow. Failure to observe this may lead to an electric shock or short-circuit, resulting in ignition.
 - To replace or repair the damaged case or other parts, contact our distributor or TOHNICHI MFG. CO., LTD. In case the product does not function successfully, turn off the power switch and contact TOHNICHI MFG. CO., LTD., Sales Department. (See the contact information at the end of this operating instruction.)

Precautions for Use

- **For correct and safe operation;**

- Do not use the product for an object exposed to repetitive impact such as an impact wrench.
- Never use other charger than the included one.
- Be sure to use the power for the charger at the voltage inscribed on the nameplate.
- Be sure to use the product within the ST3-G-BT's allowable torque range.
- Ensure that the ST3-G-BT body is reliably fit with a socket and square drive.
- Prior to use, check that the socket and square drive are free from cracks.
- Note that if the product is wetted with water or oil, it may result in trouble or burnout.
- Remember to conduct daily inspection and calibration at your specified intervals.
- Note that if the ST3-G-BT body is dropped or struck, the case may be damaged, resulting in trouble.
- Even if the product is not used for a long period, charge it semiannually and insert an accessory long-term storage power plug into the charging jack of the main body to store.

In case you notice abnormal smell or ignition during use, stop using the product, move the main body to a safe place and contact TOHNICHI MFG. CO., LTD., Sales Department. (See the contact information at the end of this operating instruction.)

Contents

1. Features	6
2. Components	7
3. Names of Parts and Descriptions	7
4. Detailed Descriptions of Various Functions	10
4-1. Continuous display (RUN mode)	10
4-2. Maximum value display (PEAK mode)	10
4-3. Auto zero function (Torque)	10
4-4. Angular velocity check and zero compensation function ...	10
4-5. Auto memory/reset function.....	11
4-6. Auto power OFF function.....	11
4-7. Remaining battery indicator function	11
4-8. Over torque alarm function	11
4-9. Over torque alarm and peak hold starting torque ...	12
4-10. List of error messages	12
5. Measurement Method	13
5-1. Measurement example (Overall flow)	13
5-2. Measurement example (Display area)	14
6. Operating Examples	16
6-1. Saving the measured data	16
6-2. Reading out the measured data.....	16
6-3. Statistical processing function.....	16
6-4. External output of measured data.....	17
6-5. Erasing the measured data memory	18
7. External Output Specifications	20
7-1. Communication specifications	20
7-2. Operation using the communication command	20
7-3. Communication format	22
7-4. Communication example	24
8. Procedures for Various Settings	25
8-1. Setting items.....	25
8-2. Various Setting Methods	26
9. Charging	28
10. Optional Accessories	29
11. Specifications	30

1 Features

- (1) World's smallest rechargeable rotary torque meter.
- (2) Cordless and attachable to a rotating body.
- (3) Attachable to a nut runner to simply check a torque value and a rotating angle from preset snug torque.
- (4) Capable of measuring torque data (waveform data) in steps of 1° and drawing waveform with an external device.
- (5) Capable of saving up to 999 measured peak data. (Only one waveform data)
The auto memory/reset function automatically saves and counts up data.
- (6) Capable of displaying the number of samples, maximum, minimum and average values of measured peak data up to an optional memory count.
- (7) Capable of wireless data transfer to a PC through Bluetooth® communication.
- (8) Use of nickel hydrogen battery allows 8-hour continuous operation (10 hours in case Bluetooth® setting is OFF). Provided with remaining battery indicator.
- (9) Capable of checking a multi-axis machine at low cost by combining with an extension bar (option) having the same length as the ST3-G-BT.
- (10) Capable of measuring a torque at narrow pitches as shown in the table below.
- (11) ST15N3-6.35-G-BT easily attachable to a bit type nut runner.

Model	Min. Center Distance	
	(1)	(2)
ST10N3-G-BT to ST200N3-G-BT (except for ST15N3-6.35-G-BT)	40mm	50mm
ST500N3-G-BT	55mm	70mm
ST1000N3-G-BT	60mm	

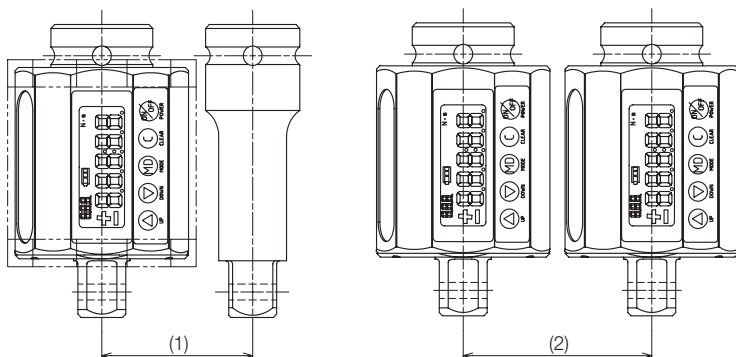

2 Components

- (1) Main body
- (2) Charger BC-4-2
- (3) Long-term storage power plug
- (4) Power conversion plug
- (5) Carrying case
- (6) Operating instruction

* One each

3 Names of Parts and Descriptions

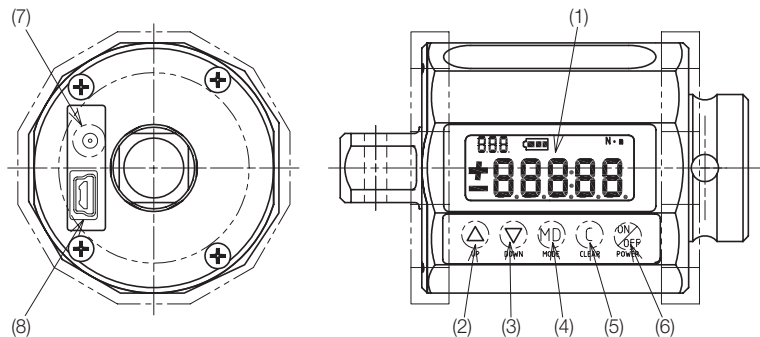

(1) Liquid Crystal Display

Displays a memory count, auto memory, remaining battery capacity, unit, torque value and rotating angle.

(2) : Count Forward Key

Increments a memory count by 1 or continuously to read out measured data. The memory count is incremented in steps of 10 by holding down the key.

(3) : Count Backward Key

Decrements a memory count by 1 or continuously to read out measured data. The memory count is decremented in steps of 10 by holding down the key.

(4)  : Mode Key

Switches between torque value display and rotating angle display when snug torque has been set. If the key is held down for 2 seconds at the memory count of 000, various settings are made.

If held down for 2 seconds at the memory count of 001 to 999, the display switches among arithmetic start position, number of samples, maximum value, minimum value and average value.

(5)  : Clear Key

Resets a peak display value in the peak torque display state or clears saved measured data. Performs auto zeroing in the run display state.

(6)  : Power Switch

Power on/off switch. Key check is conducted at power-on time. In case the snug torque has been set or the memory count is 000, angular velocity is also checked. After power-on, bring the ST3-G-BT to rest immediately.

If this key is pressed with the power turned on, the display power is turned off. Hold it down for 2 seconds or more to turn off Bluetooth®.

(7) **Charging Jack**

Terminal where the charger BC-4-2 is connected to charge the battery. Upon delivery, the long-term storage power plug has been inserted for discharge prevention. Remove it before use. When the product is not used for a long period, insert the long-term storage power plug to store.

(8) **External Output Terminal (Used by the manufacturer)**

Not used for the ST3-G-BT model.

[Details of Display Area]

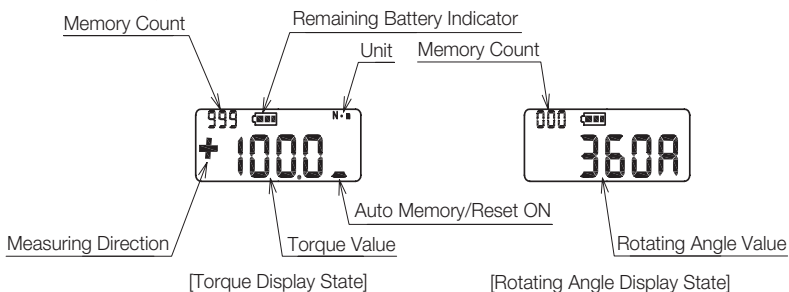

[Details of Bluetooth® Display Area]

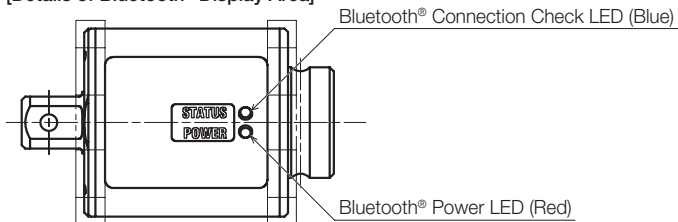

• Bluetooth® power LED

In case the Bluetooth® power is turned on, the red LED is lighted. If the power switch is held down for 2 seconds with torque display lighted, the power LED is unlighted.

• Bluetooth® connection check LED

The blue LED is lighted when connection between the ST3-G-BT and an external device is established, and unlighted when disconnected.

4 Detailed Descriptions of Various Functions

4-1. Continuous display (RUN mode)

With the memory count being 000, the displayed torque increases by applying a torque load and returns to 0 by cancelling the load.

Press the **MD** key to switch to the rotating angle display. The angle increases by turning the ST3-G-BT to the right in the rotating angle display state and decreases by turning to the left. If the ST3-G-BT stands still for 2 seconds or more, the angle display is automatically cleared to 0.

4-2. Maximum value display (PEAK mode)

With the memory count being 001 to 999, the displayed torque increases by applying a torque load, and even if the load is cancelled, the maximum torque value is displayed on hold (peak hold). In the case of approx. 3.3% or less of the maximum measured torque, however, the RUN mode results. In case the snug torque has been set and is exceeded, the display switches to the rotating angle display state to display the rotating angle.

4-3. Auto zero function (Torque)

In case a torque load is within approx. 7.5% of the maximum measured torque in the continuous display state (RUN mode), the auto zero function is activated by pressing the **C** key. In case the torque load is greater than approx. 7.5% of the maximum measured torque, "Err9" is displayed.

In case "Err9" is displayed, take the load off the ST3-G-BT and press the **C** key again. (See 4-10. List of error messages.)

4-4. Angular velocity check and zero compensation function

In case the snug torque has been set in the continuous display state (RUN mode) or maximum value display state (PEAK mode), angular velocity is checked, followed by zero compensation by "turning on the power", "transitioning from the setting mode to the measurement mode", or "transitioning from the arithmetic mode to the measurement mode".

During angular velocity check, a bar moves in the display area. If the angular velocity is stable, "good" appears; "Err0" is displayed unless the ST3-G-BT body is standing still during check.

In case "Err0" is displayed, turn off and on the power again, and then, bring the ST3-G-BT to rest without delay. (See 4-10. List of error messages.) Angular velocity check and zero compensation can be implemented by a request command from the external device. (See Chapter 8.)

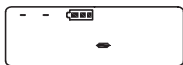
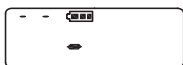
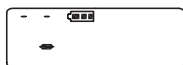

4-5. Auto memory/reset function

If the no-load state results after holding the maximum value (peak hold), a measured value is automatically saved within an optional range of setting value (after 0.1 to 5 seconds) to increment the count by 1. Once Bluetooth® communication is established, measured peak data or waveform data is sent to the external device. In case an overtorque is applied, however, a peak measured value is not saved. Set 0.0 seconds in case the auto memory/reset function is not used.





4-6. Auto power OFF function

During the set time, the power is turned off with no keys being operated or no torque load being applied (7.5% or less of the maximum measured value). Upon delivery, the auto off timer has been set to 3 minutes.

In the alarm state “- - - -”, the power is turned off in one minute regardless of the above-mentioned state.

4-7. Remaining battery indicator function

The LCD indicates the remaining battery status in 4 steps.

Remaining Battery Indicator	Battery State
	The battery has a sufficient remaining capacity.
	The remaining battery capacity is decreasing to approx. 50%.
	It is about time to charge.
	The battery is running out. Charge immediately. The LCD displays “- - - -” and you can operate only the power switch. Once in this state, the power is turned off in one minute. The saved data and various settings remain stored if the battery runs out.

4-8. Over torque alarm function

In the case of exceeding approx. 105% of the maximum measured torque, the LCD alternately displays the torque or rotating angle and “- - - -”.

4-9. Over torque alarm and peak hold starting torque

Model	Torque Range [N·m]		1 digit	More than Approx. 105% of Max. Measured Torque	More than Approx. 3.3% of Max. Measured Torque	More than Approx. 7.5% of Max. Measured Torque
	Min.	Max.		Overtorque Alarm	Peak Hold Start Torque	Range of Auto Zero
ST10N3-G-BT	(0.50)2.00	10.00	0.01	10.50	0.33	0.77
ST15N3-6.35-G-BT	(1.00)4.00	15.00	0.02	15.75	0.50	1.15
ST20N3-G-BT	(1.00)4.00	20.00	0.02	21.00	0.67	1.54
ST50N3-3/8-G-BT	(2.50)10.00	50.00	0.05	52.50	1.67	3.85
ST50N3-1/2-G-BT	(2.50)10.00	50.00	0.05	52.50	1.67	3.85
ST100N3-G-BT	(5.0)20.0	100.0	0.1	105.0	3.3	7.7
ST200N3-G-BT	(10.0)40.0	200.0	0.2	210.0	6.7	15.4
ST500N3-G-BT	(25.0)100.0	500.0	0.5	525.0	16.7	38.5
ST1000N3-G-BT	(50)200	1000	1	1050	33	77

Note: Parenthesized values are minimum set values of snug torque.

There is no assurance for accuracy of snug torque values less than the minimum torque in the torque range.

4-10. List of error messages

Error	Description	Remedy
Err0	Defective angular velocity detecting section	After turning off and on the power again, bring the ST3-G to standstill. If the error is reset, the product is operable again. If not reset, the angular velocity detecting section is defective. Contact our distributor or TOHNICHI MFG. CO., LTD.
Err1 to Err5	A surface switch remains pressed.	Turn off and on the power again without touching the surface switch. If the error is reset, the product is operable again. If not reset, the switch is defective. Contact our distributor or TOHNICHI MFG. CO., LTD.
Err8	The CPU or memory is defective.	Contact our distributor or TOHNICHI MFG. CO., LTD.
Err9	The torque zero width is exceeded. (The torque sensor or internal circuit is defective.)	With no load being applied, press the C key. If the error is reset, the product is operable again. If not reset, the torque sensor or internal circuit is defective. Contact our distributor or TOHNICHI MFG. CO., LTD.



5 Measurement Method

5-1. Measurement example (Overall flow)

- (1) Prior to using the ST3-G-BT, turn on the power and check the battery has a sufficient remaining capacity. If a battery mark blinks, charge the battery.

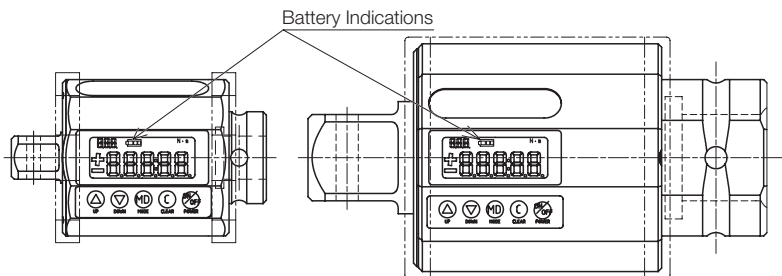
Make various settings. (See 8. Procedures for Various Settings.) Particularly, when measuring an angle, set a snug torque.



- (2) Attach the ST3-G-BT to the square drive of a torque product. In the case of a multi-axis machine, etc., attach an extension bar (optional), a substitute for the ST3-G-BT, to the end of other torque product and adjust a distance to a work object. To attach the ST3-G-BT and extension bar, use O-ring and pin.
- (3) Attach a socket to the square drive of the ST3-G-BT/extension bar, using a pin and O-ring.
- (4) Press the power switch  of the ST3-G-BT. Check that the memory count is other than 000. In the case of 000, press the  or  key to change the count to 001, etc. to effectuate the maximum value display state (PEAK mode). When you want to output a measured value at every time of measurement, establish connection of Bluetooth® communication.

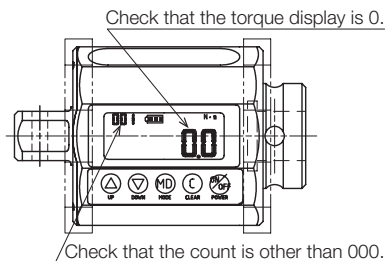
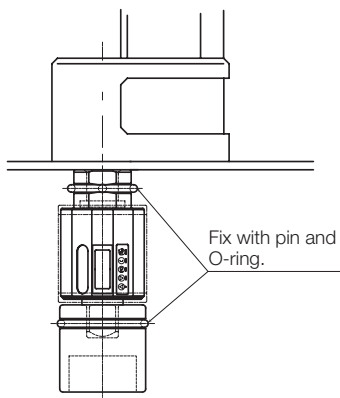

- (5) Tighten the work object with the torque product.

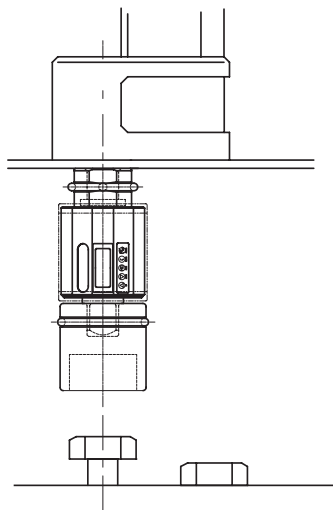

- (6) Measure the required number of data (up to 999). The measured data values are automatically saved and counted up by the auto memory/reset function, allowing continuous measurement.

When saving measured peak data with Bluetooth® communication established, the measured data is simultaneously transmitted.

* In case “ST3-S” is set as an external output format, waveform data is output.

- (7) Once measurement is completed, remove the ST3-G-BT and check the saved data.

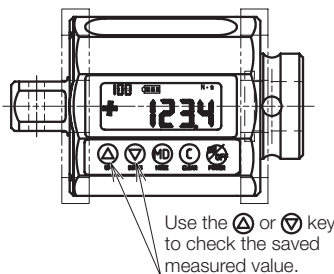

5-2. Measurement example (Display area)

Ex. 1) Torque tightening measurement

In case the snug torque is set to 0, peak torque measurement is implemented.

- (1) Start measurement.



- (2) Once measurement starts, a torque value increases.



- (3) After measurement is completed, cancel the load. In case the auto memory/reset function has been set, the measured value is automatically saved and counted up to prepare for next

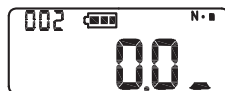

measurement. If not set, check the measured value and press the Δ key. The measured value is saved and counted up to prepare for next measurement. When saving measured peak data with Bluetooth® communication established, the measured data is simultaneously transmitted.

* In case "ST3-S" is set as an external output format, waveform data is output.

Ex. 2) Rotating angle tightening measurement

In case the snug torque is set, the rotating angle is measured based on the peak torque and snug torque.

* In the case of the snug torque of 5.0 N·m

(1) Once measurement starts, a torque value increases.

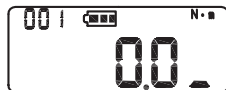

(2) After reaching the snug torque, the rotating angle display appears to start counting the angle.

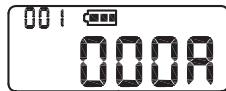

(3) After measurement is completed, cancel the load. In case the auto memory/reset function has been set, the measured value is automatically saved and counted up to prepare for next measurement. If not set, check the measured value and press the Δ key. The measured value is saved and counted up to prepare for next measurement. When saving measured peak data with Bluetooth® communication established, the measured data is simultaneously transmitted.



* In case "ST3-S" is set as an external output format, waveform data is output.

6 Operating Examples

6-1. Saving the measured data

Save the measured data.

After measurement, press the \triangle key. If there is a measured value, it is saved in the ST3-G-BT, simultaneously incrementing the memory count. It is not erased if the power is turned off. Once the auto memory/reset function is set, the measured value is automatically saved after measurement.

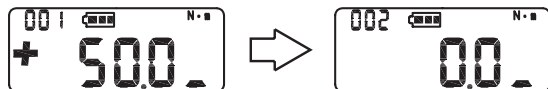

6-2. Reading out the measured data

Read out the saved measured data.

(1) In case the \triangle or ∇ key is pressed, the memory count is incremented or decremented to read out the relevant measured data.

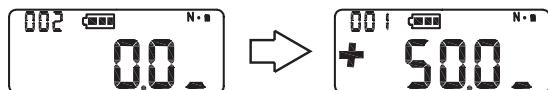

(2) In case the MD key is pressed with the snug torque being set to other than 0, the display state is switched between torque display and rotating angle display.

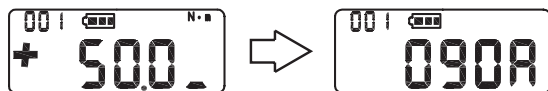

6-3. Statistical processing function (Number of samples, maximum value, minimum value, average value)

Statistically process and display the specified range of measured data such as number of samples, maximum, minimum and average torque values.

(1) Use the \triangle or ∇ key to display the final memory count of the range you want to statistically process.



(2) Hold down (2 seconds) the MD key to display "Stt". Use the \triangle or ∇ key to display the first count value you want to statistically process.



- (3) Press the **MD** key to display the number of samples “n”, maximum value “HI”, minimum value “Lo” and average value “AV” in that order.



- (4) Press the **MD** key again to return to the measurement display state. If the **C** key is pressed halfway the arithmetic display state, control returns to the measurement display state.



6-4. External output of measured data

* See Chapter 7 for the external communication method by external communication commands.

* See Chapter 8 for the method for setting the ST3-G-BT body.

6-4-1. Output of single measured peak data

Output a measured peak torque value and rotating angle data to the external device.

- (1) Set the external output format to “ST3” (factory setting) or “ST2”.
- (2) Establish Bluetooth® communication between the ST3-G-BT and external device.
- (3) Once the auto memory/reset function is activated after measurement, measured data is output.

6-4-2. Output of waveform data

Output measured torque data in steps of 1° to the external device.

- (1) Set the external output format to “ST3-S”.
- (2) Establish Bluetooth® communication between the ST3-G-BT and external device.
- (3) Once the auto memory/reset function is activated after measurement, measured data is output.

6-4-3. Batch output of measured data

Output a specified range of measured peak data collectively to the external device.

* See Chapter 7 for the output method by external communication commands.

* See Chapter 8 for the method for setting the ST3-G-BT body.

- (1) Establish Bluetooth® communication between the ST3-G-BT and external device.
- (2) Conform the communication conditions (data length: 8 bits, stop bits: 1 bit) of the external device to those of the ST3-G-BT.
- (3) Use the \triangle or ∇ key to display the final memory count of the desired external output range.



- (4) Hold down (2 seconds) the MD key to display "Stt". Use the \triangle or ∇ key to display the first count value you want to externally output.



- (5) Press the MD key to display the number of samples "n". Press the \triangle key to externally output.



- (6) Press the C key to return to the measurement screen.



6-5. Erasing the measured data memory

Erase saved measured peak data.

* See Chapter 7 for the erasing method by external communication commands.

6-5-1. Erasing single data

Use the \triangle or ∇ key to display the data corresponding to the memory count you want to erase. Press the C key to erase the measured data.

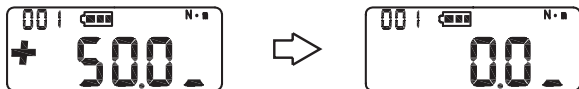

6-5-2. Erasing the specified range of data

- (1) Use the \triangle or ∇ key to display the final memory count of the range you want to erase.



- (2) Hold down (2 seconds) the **MD** key to display "Stt". Use the **▲** or **▼** key to display the first count value you want to erase.



- (3) Press the **MD** key to display the number of samples "n".



- (4) While pressing the **MD** key, press the **C** key to erase the data. If the **C** key is pressed with the **MD** key being not pressed, control returns to the measurement state.



* Examples of erasing the specified range

Ex. 1) When erasing the memory range of 001 to 200

Set the count to 200, press the **MD** key and set Stt to 001.

Ex. 2) When erasing the memory range of 101 to 200

Set the count to 200, press the **MD** key and set Stt to 101.

Ex. 3) When erasing all the measured data

Set the count to 999, press the **MD** key and set Stt to 001.



In one of the above display states, press the **C** key together with the **MD** key. Release the two keys.

Then, the following display appears, completing data erasure.

After completion, control returns to the measurement display state.



7 External Output Specifications

7-1. Communication specifications

(1) Bluetooth® communication specifications

Bluetooth® Version	V3.0
Transmission System	AFH
Modulation System	GFSK
Wireless Output	4dBm
Transmission Power Class	Class2
Profile	SPP
Communication Distance	Approx. 10 m* expected
Certified By	TELEC/FCC/IC/CE

* The communication distance differs depending on the radio wave environment and the performance of the communication target device.

(2) Communication conditions

Baud Rate	Dependent on the host device side.
Parity	None
Data Length	8 bits
Stop Bits	1 bit
Flow Control	Hardware (RTS/CTS)

* You may be requested to input a PIN code or passcode, depending on the device connected. Input "0000" in that case.

7-2. Operation using the communication command

The ST3-G-BT can be operated by sending communication commands from the external device side.

* See 6-4 for the communication methods using no external commands.

7-2-1. List of communication commands

Command	Function
W0	Turns off the power. BT communication remains connected.
W1	Turns on the power.
W2	Checks the power status.
W3	Collectively transmits the measured peak data ranging from 001 to the displayed memory count.
W4	Transfers single measured data being displayed.
W5	Outputs waveform data.
W6	Interrupts collective transfer of measured peak data and output of waveform data.
W7	Erases measured data.
W8	Checks the angular velocity.
W9□□□□	Sets the snug torque.
WM	Returns the model name of the ST3-G-BT.

* All the commands are of the ASCII code.

* Suffix the commands with "CRLF".

7-2-2. Operations by communication commands

(1) Power-on/-off by Bluetooth® communication

In case the command "W0CRLF" is sent from the Bluetooth® device connected to the ST3-G-BT, the liquid crystal screen is turned off, transitions to the sleep mode, thereby saving the power. In case the command "W1CRLF" is sent, the screen is turned on, being reverted from the sleep mode, and enabled for measurement.

To check the power status of the ST3-G-BT, send "W2CRLF" and the power status is returned by a command.

* This command keeps Bluetooth® connection and does not turn off the ST3-G-BT completely.

(2) Batch output of measured data by Bluetooth® communication

In case the command "W3CRLF" is sent from the Bluetooth® device connected to the ST3-G-BT, the measured data are collectively output, ranging from the memory count 001 to the currently displayed count value. Output is interrupted by sending "W6CRLF" during batch output of measured data.

(3) Output of single measured data by Bluetooth® communication

Set the auto memory/reset timer to 0.0 seconds, select the memory count display to other than 000, and select the maximum value display state (PEAK mode) to make measurement. Every time "W4CRLF" is sent from the Bluetooth® device connected to the ST3-G-BT, single measured data is output.

(4) Output of waveform data by Bluetooth® communication

Set the auto memory/reset timer to 0.0 seconds, select the memory count display to other than 000, and select the maximum value display state (PEAK mode) to make measurement. Waveform data is output by sending "W5CRLF" from the Bluetooth® device connected to the ST3-G-BT. Output is interrupted by sending "W6CRLF" while outputting the waveform data.

* Only one waveform worth of data is saved; it is erased by updating the memory count.

Note that the data is overwritten in case next measurement is made.

(5) Interruption of data output

Output is interrupted by sending "W6CRLF" while collectively outputting the measured data or outputting the waveform data.

(6) Erasure of measured data by Bluetooth® communication

The measured data is erased by sending the command "W7CRLF" from the Bluetooth® device connected to the ST3-G-BT after measurement.

(7) Angular velocity check by Bluetooth® communication

Angular velocity is checked by sending the command “W8CRLF” from the Bluetooth® device connected to the ST3-G-BT after measurement.

(8) Snug torque setting by Bluetooth® communication

A snug torque value can be changed by sending the command “W9□□□□CRLF” from the Bluetooth® device connected to the ST3-G-BT. (Substitute the snug torque value for □□□□.) Adjust a decimal point position so as to conform to the display on the ST3-G-BT, and send the snug torque value.

Ex. 1) In the case of sending 0.5 N·m to the ST50N3-3/8-G-BT

Send “W90050CRLF” because the decimal point position is the 2nd digit.

Ex. 2) In the case of sending 0.5 N·m to the ST100N3-G-BT

Send “W0005CRLF” because the decimal point position is the 3rd digit.

(9) Model name check by Bluetooth® communication

The model name of the ST3-G-BT is returned by sending the command “WMCRLF” from the Bluetooth® device connected to the ST3-G-BT after measurement. The model name is returned in the form of the following commands.

Model	Model Command									
ST10N3-G-BT	S	T	1	0	N	3	CR	LF		
ST15N3-6.35-G-BT	S	T	1	5	N	3	CR	LF		
ST20N3-G-BT	S	T	2	0	N	3	CR	LF		
ST50N3-3/8-G-BT	S	T	5	0	N	3	CR	LF		
ST50N3-1/2-G-BT	S	T	5	0	N	3	CR	LF		
ST100N3-G-BT	S	T	1	0	0	N	3	CR	LF	
ST200N3-G-BT	S	T	2	0	0	N	3	CR	LF	
ST500N3-G-BT	S	T	5	0	0	N	3	CR	LF	
ST1000N3-G-BT	S	T	1	0	0	0	N	3	CR	LF

7-3. Communication format

(1) External output format: When “ST3-G-BT” is selected (ST3-G-BT to the external device)

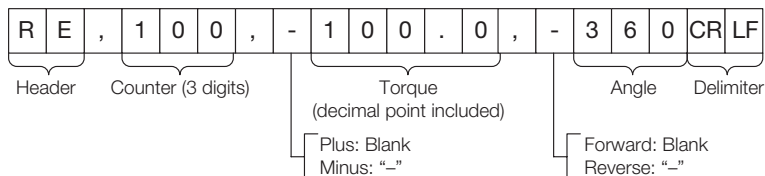

- (2) External output format: When "ST2" is selected (ST3-G-BT to the external device)
 When taking into the system, etc. using the conventional ST2, utilize this format.
 (See Chapter 8 for the setting method.)

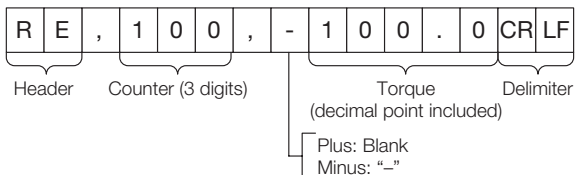

- (3) Waveform data output format: When "ST3-S" is selected (ST3-G-BT to the external device)
 (See Chapter 8 for the setting method.)

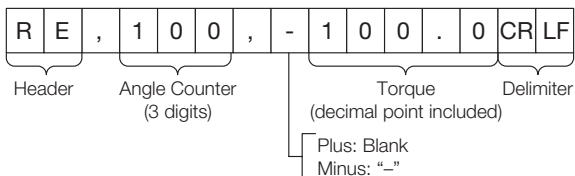

- (4) Reception command (External device to the ST3-G-BT)

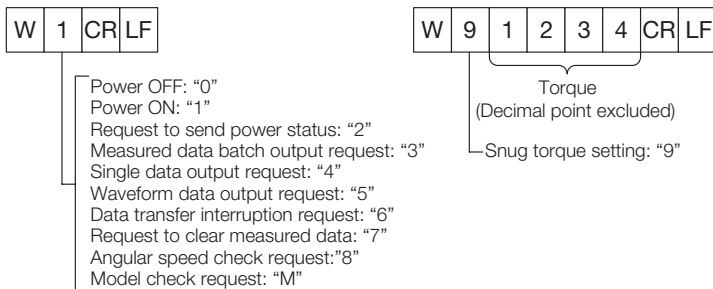

- (5) Response command (ST3-G-BT to the external device)

The status and an error command are returned after receiving a request command.

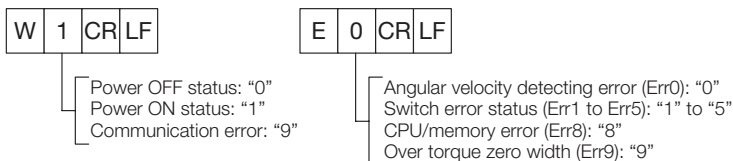

7-4. Communication example

The following introduces operation examples by the communication commands.

(1) Turn on the ST3-G-BT.

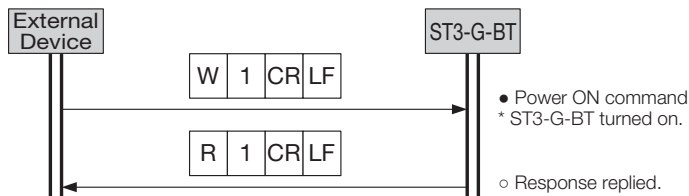

(2) Turn on the ST3-G-BT.

* When "Err0" is displayed as a result of angular velocity check;

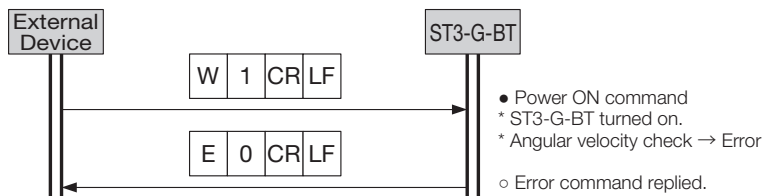

(3) Single data request

* When the measured torque value is 20.00 and angle value is 90°;

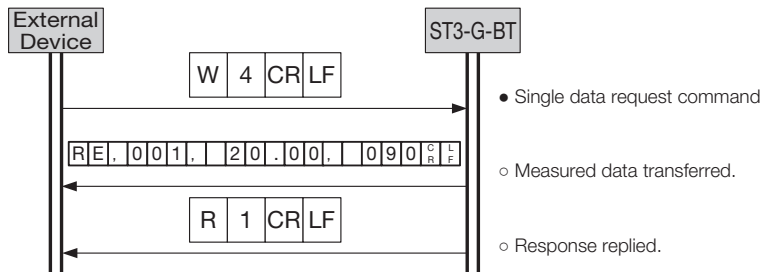

(4) Waveform data request

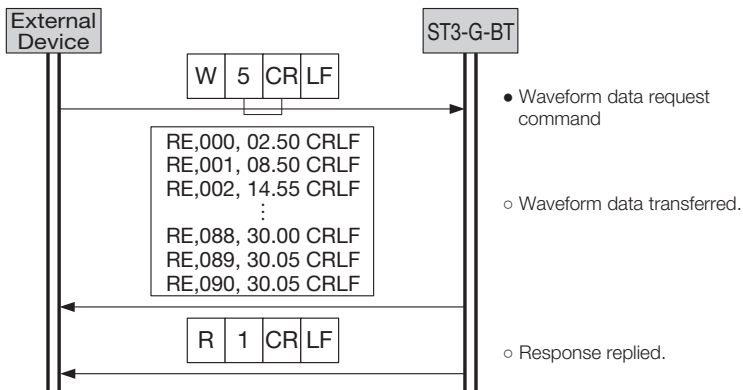

(5) Snug torque setting

* When setting the snug torque of 1 N•m to the ST50N3-3/8-G-BT;

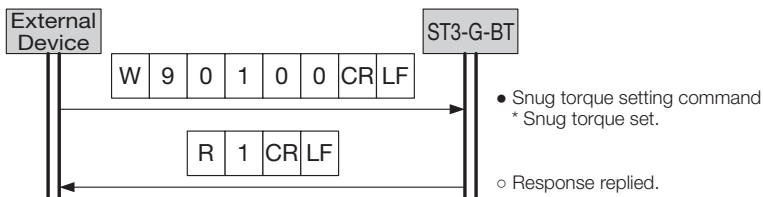

8 Procedures for Various Settings

The following describes various settings.

8-1. Setting items

	Setting Item	Count Display	Delivery Setting	Selection
1	Unit of Torque	Un	N-m	Depends on the model.
2	Snug Torque	Sng	0	Max. measured torque or less
3	Auto Memory/Reset Timer	Ar	0.0	0.1 to 5.0
4	Bluetooth® Communication Setting	do	bt	off
5	External Output Format	doF	ST3-G-BT	ST2/ST3-S
6	Auto Power Off Timer	oFF	3	10/30/nonE

8-2. Various Setting Methods

- (1) Use the \triangle or ∇ key to set the memory count to "000".

Hold down the MD key for 2 seconds to enter the various settings mode.



- (2) Setting the unit of torque measurement (N·m upon delivery)

Set the unit of torque measurement. If the setting is changed, the unit of the saved measured value is also changed.

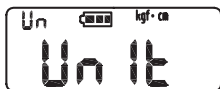
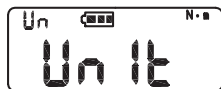

Use the \triangle or ∇ key to select the unit, press the MD key to save it, and proceed to the next step.

If the C key is pressed, control returns to the measurement display state without saving the unit.

- (3) Setting the snug torque (0 upon delivery)

Set the snug torque. Once a value is set, a rotating angle is measured based on the snug torque. If the snug torque is set to 0, the rotating angle is not measured.



Select a digit with the \triangle key and adjust a value with the ∇ key. Press the MD key to save the value, and proceed to the next step.

If the C key is pressed, control returns to the measurement display state without saving the value.

- (4) Setting the auto memory/reset timer (0.0 upon delivery)

Set the auto memory/reset timer. Once a value is set, after a lapse of time set upon cancelling a load at the end of measurement, a measured value is automatically saved and counted up to prepare for next measurement.

In the case of no auto memory/reset, set to "0.0".



(Use the \triangle or ∇ key to select the value, press the MD key to save it, and proceed to the next step.

If the **(C)** key is pressed, control returns to the measurement display state without saving the value.

(5) Bluetooth® communication setting (bt upon delivery)

Set the Bluetooth® communication. Setting to “off” disables Bluetooth® communication. Use this setting when you want to reduce power consumption or when using in a wireless communication disabled environment.



Use the **(Δ)** or **(▽)** key to select the communication, press the **(MD)** key to save it, and proceed to the next step.

If the **(C)** key is pressed, control returns to the measurement display state without saving the communication.

(6) Setting the external output format (ST3 upon delivery)

Set an external output format.

(ST3-G-BT: torque value + angle/ST2 : torque value only/ST3-S: waveform data)

In case “ST3-S” is set as the format, waveform data is output when the auto memory/reset function is activated.

Even in case “ST3” or “ST2” is set, waveform data is output upon receiving an external request command.

In case the snug torque has been set to “0” with ST3-S by default, angle output is “0”.

In case a numerical value has been set for the snug torque and ST2 is selected, no angle data is output.



Use the **(Δ)** or **(▽)** key to select the format, press the **(MD)** key to save it, and proceed to the next step.

If the **(C)** key is pressed, control returns to the measurement display state without saving the format.

(7) Setting the auto power off timer (3 upon delivery)

Set an auto power off time. (3: 3 min., 10: 10 min., 30: 30 min., nonE: none)

In case there is no key operation or torque load during the set time, the display of ST3-G-BT disappears automatically.

If "nonE" is selected, the power remains turned on until it is turned off with the ON/OFF key or the battery runs out.



Use the Δ or ∇ key to select the time, press the MD key to save it, and proceed to the next step.

If the C key is pressed, control returns to the measurement display state without saving the time.

9 Charging

(1) Connect the power plug of the charger to a plug socket.

When this is done, a charge completion lamp and a charging lamp are respectively turned on for approx. 0.5 seconds in that order in order to confirm that they function properly.

(2) Connect the DC plug of the exclusive charger (BC-4-2) to the charging jack of the ST3-G-BT.

(3) Once charging starts, the charging lamp of the charger is turned on.

(4) Once charging is completed, the charging completion lamp of the charger is turned on.

(5) After charging is completed, disconnect the charger from the plug socket, followed by the DC plug from the charging jack of the ST3-G-BT.

Caution

- In case the DC plug is disconnected during charging and connected again to resume charging, the red lamp of the charger may blink at shorter intervals. In this case, disconnect the charger from the plug socket and connect again. This resumes successful charging.
- The battery life depends on the operating conditions, but is approx. 500 times in terms of the number of charge and discharge.
- At the time of delivery, the battery has been discharged. Use the charger (BC-4-2) to charge it for use.

Warning

- Ensure that the power for the charger is of the voltage inscribed on the nameplate.
- Overcharge shortens the battery life. Once the completion lamp of the charger is turned on, stop charging without delay.

- The product is not available with the charger connected.
- In case any abnormality occurs during charge, the red lamp of the charger blinks at shorter intervals. Disconnect the charger from the plug socket and connect it again. If the abnormality still persists, contact our distributor or TOHNICHI MFG. CO., LTD.
- Charge the battery between 10 and 40°C.
- In case abnormal smell or heating is noticed during operation by any chance, stop using the product immediately, move the main body to a safe place and contact TOHNICHI MFG. CO., LTD.
- Even if the product is not used for a long period, charge it semiannually, connect the accessory long-term storage power plug to the charging jack of the main body and store.

10 Optional Accessories

Extension bar

Catalog No.	Applicable Model
No.283	ST10N3-G-BT
No.281	ST20N3-G-BT
	ST50N3-3/8-G-BT
No.247	ST50N3-1/2-G-BT
	ST100N3-G-BT
	ST200N3-G-BT
No.248	ST500N3-G-BT
No.249	ST1000N3-G-BT



Calibration kit

Model	Applicable Model
TCL50N	ST10N3-G-BT, ST20N3-G-BT ST50N3-3/8-G-BT, ST50N3-1/2-G-BT
TCL200N	ST100N3-G-BT, ST200N3-G-BT
TCL800N	ST500N3-G-BT
TCL1000N	ST1000N3-G-BT



Note 1: To calibrate ST10N3-G-BT, adapter 3H-2 (Catalog No. 271) is required.

Note 2: To calibrate ST50N3-1/2-G-BT, adapter 3H-4 (Catalog No. 272) is required.

Note 3: ST15N3-6.35-G-BT is not available to calibrated with TCL. Contact TOHNICHI when calibration required.

11 Specifications

■ ST10N3-G-BT to ST1000N3-G-BT

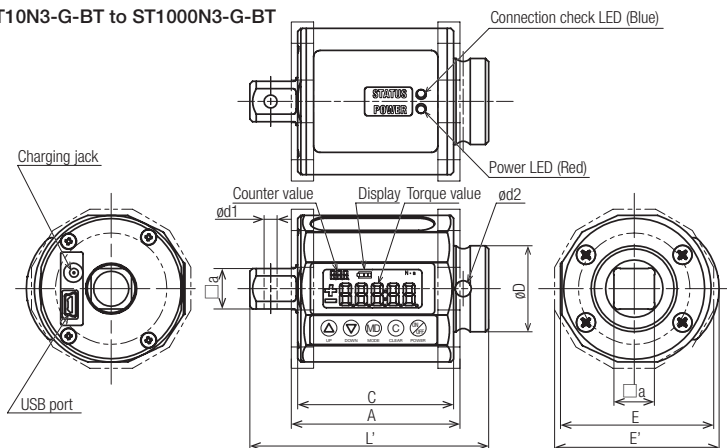

■ ST15N3-6.35-G-BT

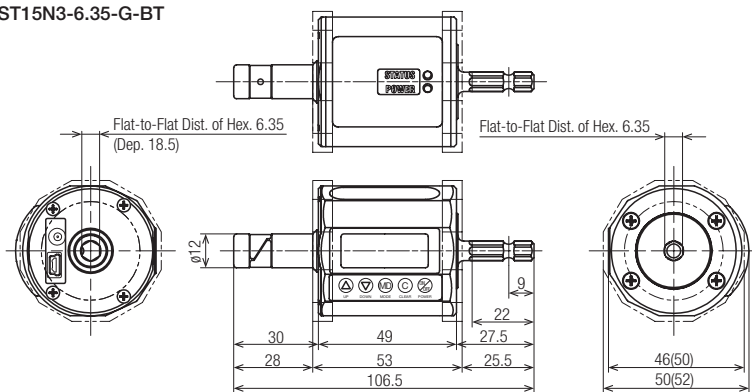

Model	Dimension [mm]									Weight [kg]
	L'	E	C	øD	□a	øD1	øD2	A	E'	
ST10N3-G-BT	75	46	49	13	6.35	2.1	2.1	53	50	0.25
ST15N3-6.35-G-BT	106.5			-	-	-				
ST20N3-G-BT				18	9.53	3.1				
ST50N3-3/8-G-BT	75			27	12.7	4.1	5			
ST50N3-1/2-G-BT										
ST100N3-G-BT										
ST200N3-G-BT										
ST500N3-G-BT	120	67	73	38	19.05	6	6	78	71	1.3
ST1000N3-G-BT	135			51	25.4					

■ Common Specifications

Accuracy	±1% +1 digit
Angle Measurement Range	0 to 999°
Angle Accuracy	±2° + 1 digit (when rotated by 90° at 30°/sec. to 600°/sec.)
Direction	Right and left
Display	7-segment LCD display Memory count value: 3 digits (character height: 3 mm), Torque/rotating angle display: 4 digits (character height: 7 mm) Unit, Remaining battery capacity, Measuring direction
Measurement Mode	PEAK/RUN
Data Memory	999
Arithmetic Function	Number of samples, maximum, minimum and average values
Power	Nickel hydrogen battery pack
Continuous Operating Hours	Approx. 10 hours
Charger	Input: 100 to 240 V AC ± 10% (conforming to PSE, compliant with CE)
Charging Time	Approx. 2 hours
Other Functions	Auto memory/reset (0.5 to 5 seconds variable), Auto zero Auto power-off (3/10/30 min./none selectable), Remaining battery indicator display (4 levels)
Operating Temperature Range	0 to 40°C

ST3-G-BT Communication Specifications	
Communication System	Bluetooth®
Wireless Communication Distance	10m
Continuous Operating Time	BT off: Approx. 10 hours BT on: Approx. 8 hours

Bluetooth® is a registered trademark of Bluetooth SIG, Inc.

■ Setting Limits for ST3-G-BT

Model	N·m			cN·m			kgf·cm			kgf·m			lbf·in			lbf·ft			ozf·in		
	Min.	Max.	1 digit	Min.	Max.	1 digit	Min.	Max.	1 digit	Min.	Max.	1 digit	Min.	Max.	1 digit	Min.	Max.	1 digit	Min.	Max.	1 digit
ST10N3-G-BT	2.00-10.00	0.01		200-1000	1		20.0-100.0	0.1		0.200-1.000	0.001		17.6-88.0	0.1		1.50-7.30	0.01		280-1400	1	
ST15N3-6.35-G-BT	4.00-15.00	0.02		400-1500	2		40.0-150.0	0.2		0.400-1.500	0.002		35.0-132.0	0.2		3.00-11.00	0.02		560-2100	2	
ST20N3-G-BT	4.00-20.00	0.02		400-2000	2		40.0-200.0	0.2		0.400-2.000	0.002		35.0-175.0	0.2		3.00-14.50	0.02		560-2800	2	
ST50N3-3/8-G-BT ST50N3-1/2-G-BT	10.00-50.00	0.05		1000-5000	5		100.0-500.0	0.5		1.000-5.000	0.005		88.0-440.0	0.5		88.0-440.0	0.5		1400-7000	5	
ST100N3-G-BT	20.0-100.0	0.1	-	-	-	-	200-1000	1		2.00-10.00	0.01		176-880	1		15.0-73.0	0.1		-	-	
ST200N3-G-BT	40.0-200.0	0.2	-	-	-	-	400-2000	2		4.00-20.00	0.02		350-1750	2		30.0-145.0	0.2		-	-	
ST500N3-G-BT	100.0-500.0	0.5	-	-	-	-	1000-5000	5		10.00-50.00	0.05		880-4400	5		75.0-365.0	0.5		-	-	
ST1000N3-G-BT	200-1000	1	-	-	-	-	-	-		20.0-100.0	0.1		-	-		150-735	1		-	-	

* "-" indicates that no value is settable.

Designs and specifications are subject to change without notice.



■ TOHNICHI MFG. CO., LTD.

TEL: +81-(0)3-3762-2455 FAX: +81-(0)3-3761-3852
2-12, Omori-kita, 2-Chome Ota-ku, Tokyo 143-0016, JAPAN
E-mail: overseas@tohnichi.co.jp
Website: <http://www.global-tohnichi.com>

■ N. V. TOHNICHI EUROPE S. A.

TEL: +32-(0)16-606661 FAX: +32-(0)16-606675
Industrieweg 27 Boortmeerbeek, B-3190 Belgium
E-mail: tohnichi-europe@online.be
Website: <http://www.tohnichi.be>

■ TOHNICHI AMERICA CORP.

TEL: +1-(0)847-947-8560 FAX: +1-(0)847-947-8572
1303 Barclay Blvd. Buffalo Grove, IL 60089 U. S. A.
E-mail: inquiry@tohnichi.com
Website: <http://tohnichi.com>

■ TOHNICHI AMERICA CORP. - Atlanta Office

TEL: +1-(0)678-423-5777 FAX: +1-(0)678-423-1333
4046 Hwy. 154 Suite 103 Newman, GA 30265

■ TOHNICHI SHANGHAI MFG. CO., LTD.

东仁扭矩仪器(上海)有限公司
TEL: +86-(021)3407-4008 FAX: +86-(021)3407-4135
Rm. 5 No. 99 Nongtong Road, Du Hui Road.
Minhang, Shanghai. P.R. China